

DIRECT COMBINATION OF THERMOGRAVIMETRIC ANALYSER AND ATOMIC ABSORPTION SPECTROMETER FOR DETECTION OF ATOMIC VAPOUR IN THERMAL ANALYSIS

KAZUYUKI NAGAYAMA and TAKEO TAKADA *

Department of Chemistry, Rikkyo (St. Paul's) University, Nishi-Ikebukuro, Toshima-ku, Tokyo 171 (Japan)

(Received 28 March 1989)

ABSTRACT

A thermogravimeter was combined with an atomic absorption spectrometer. The atomic absorption could be measured simultaneously with the thermogravimetric changes under identical conditions. Optimum experimental conditions were determined using solid mercury halides and mercury(II) nitrate, by varying the sample weight and the flow rate of the carrier gas. The absorbance versus temperature curves obtained with this system for mercury halides and nitrate are compared with the corresponding thermograms. This apparatus may be useful in obtaining much more information concerning the gases evolved in thermogravimetry and the atomization processes of many metal-containing substances in atomic absorption spectrometry.

INTRODUCTION

Thermogravimetry (TG) is widely used to investigate thermal volatilization processes. This method involves the continuous measurement of the change in mass loss of the sample in the solid state with temperature. Such data have been used to determine volatilization species, such as molecular species.

In contrast, when atomic absorption spectrometry (AAS) is applied to chemical analysis, at least part of the sample must be converted into free gaseous atoms. This atomization process, however, is a very complicated phenomenon. It involves many physical and chemical processes, including volatilization of solid samples, dissociation of gaseous molecules and association between the atomic and molecular species in the gaseous state. As a result, the free neutral atom concentration primarily depends on the chemical form of the sample in the solid state and on the temperature.

* Author to whom correspondence should be addressed.

A number of papers have been published which examine atomization processes of metal-containing compounds in the flame [1] and graphite furnace [2]. These processes, however, are mainly studied using the AA or emission signals obtained in only the high temperature range, because it is difficult to identify the volatilized and dissociated substances over the whole temperature range [3]. Other reported aspects of the use of atomic spectrometry for thermal analysis are the studies of evolved gases of metal-containing species [4,5].

To elucidate the series of processes involved, starting from the solid samples or aqueous solution of samples and resulting in the atoms, a combined TG analyser and AA spectrometer was designed. Kántor and his co-workers have made such an apparatus [6,7]. In their apparatus, however, the substances evolved in the furnace of the TG device were carried into an atomizer, such as the flame of the AAS device, by a carrier gas. The evolved gases sometimes condensed and were adsorbed during passage through the tube connecting the AAS and TG devices, because of the cooling effect. Each gaseous substance, including metal atoms, evolved from the sample was detected as an AA signal. In their apparatus, this signal is independent of the composition of the atomic or molecular vapour. Hence, the usefulness of the apparatus in the study of this process was not fully exploited.

Therefore, we made the light path of the AAS source pass directly through the furnace of the TG device. In our apparatus, the TG changes, such as temperature and mass loss, and the atomic absorption spectrum of some substances were measured under identical conditions. Therefore, this system provides useful thermoanalytical and atomic absorption information for metal-containing compounds. In this paper, the modification of the apparatus and the optimization of the experimental conditions are described. Some examples using mercury compounds are also described.

EXPERIMENTAL

Combination of an AA spectrometer and a TG analyser

AA measurements were made with a dual-channel atomic absorption spectrometer which was designed in our laboratory and assembled by Nippon Jarrell–Ash [8]. The commercially available Shimazu TG equipment system (consisting of thermobalance TGC-30 and gravity-amplifier TG-30), and a Shimazu thermal analyser (model DT-30 B) were modified to allow their combination. A schematic diagram of the combined system is shown in Fig. 1. The system has four main sections designed to vaporize the sample in the furnace, to detect the analyte atomic wavelength of interest, to measure the change in mass and to control the temperature of the furnace. In the present system, the hollow cathode lamp source and the AA spectrometer

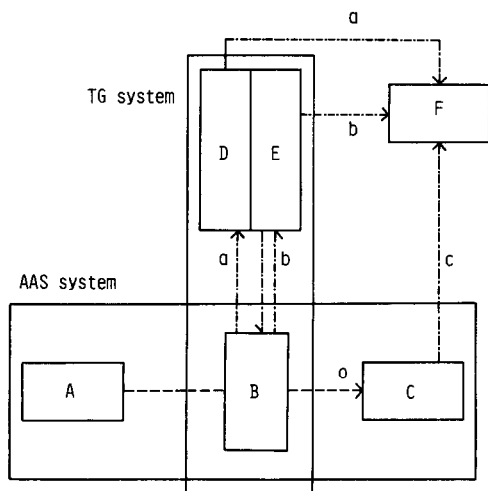

Fig. 1. Block diagram of TG and AAS combined system: (A) hollow cathode lamp source; (B) electric furnace; (C) AAS detector; (D) TG measurement system; (E) temperature control system; (F) 3-pen recorder; (a) weight change; (b) temperature change; (c) AA change; (o) light path.

detector are used in the ordinary way. The furnace of the TG analyser is used as the atomization equipment instead of the flame of the AA spectrometer. A Shimazu DT-30B temperature programming and readout system was used for all the experimental work. The light from the light source passes through a small hole in the furnace and falls onto the slit of the monochromator. The temperature of the furnace can be controlled to increase linearly from room temperature to 650°C using this system. The linearity and reproducibility of the temperature program were found satisfactory. A Shimazu (model R-123T) 3-pen recorder was used to record simultaneously the results of the changes of the furnace temperature, the TG signal and the AA signal.

Figure 2 shows a cross-section of the furnace of the TG device. The furnace was made from ceramic in a cylindrical form (22 mm i.d., 2 mm thick and 700 mm long). Heating is by kantal line electric heating wire coiled around the furnace. Holes (3 mm i.d.) were made in the sides of the furnace and there is a double stainless steel shield which prevents heat diffusion, just at the height of the sample vessel, as shown in Fig. 2. The light from the hollow cathode lamp passes through these holes and the AA signal is measured.

The sample is placed in a platinum or quartz vessel (4 mm i.d., 2 mm depth). Then the vessel is hung from the quartz wire of the thermobalance, and the changes in mass of the sample are measured. The sample temperature is measured by a chromel/alumel thermocouple mounted 3 mm under the sample vessel. After modification of the furnace it was confirmed that

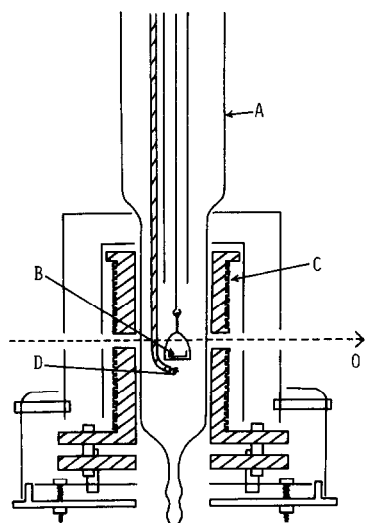

Fig. 2. Cross-section of the electric furnace: (A) quartz cuvette; (B) sample cell; (C) ceramic furnace; (D) thermocouple; (O) light path.

the temperature could be controlled to increase linearly. The atmosphere inside the quartz flow cuvette separating the sample chamber from air can be changed. Nitrogen was used as the carrier gas.

RESULTS AND DISCUSSION

Optimization of the experimental conditions

For AA-TG measurements, two types of quartz flow cuvettes, illustrated in Fig. 3(a and b), were tested for AA detection. Solid mercury(II) nitrate was measured into the sample vessel. Nitrogen carrier gas at a flow rate of 30 ml min^{-1} , and a furnace heating rate of $20^\circ\text{C min}^{-1}$ were used. In operation, the inlet port in the furnace for the carrier gas is above the centre of the cuvette, and thus the carrier gas might flow in the cuvette as shown in Fig. 3(a and b). Therefore, the products probably flow into the gas outlet with the carrier gas. In the type of cuvette on the left, the reproducibility of the AA-temperature curve of the thermally evolved mercury vapour was invariably poor with the given conditions. Some of the mercury vapour was volatilized and entered the optical path, and was then rapidly eliminated by the carrier gas. But the rest of the vapour may have passed through the optical path twice or more with the carrier gas. This may be why the results were unsatisfactory. On the other hand, highly reproducible results can be obtained with the other type of cuvette, on the right, with the given conditions. Therefore, in our present studies, the cuvette with the low

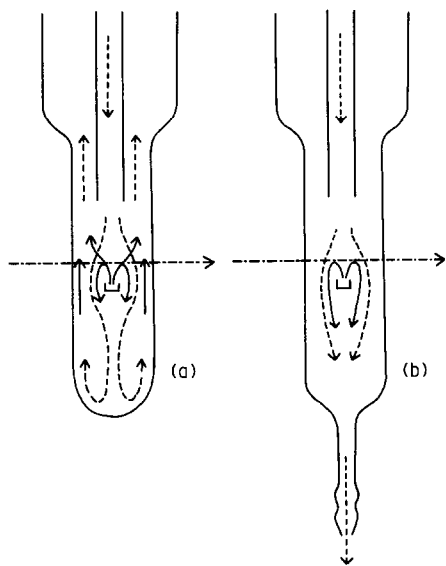

Fig. 3. Two types of quartz cuvettes for detection of atomic vapours and sketches of carrier gas and atomic vapour flow.

gas-outlet was used for detecting the mercury vapour evolved in the furnace by AAS, as well as for detecting the mass loss of the sample in the furnace by TG.

The sensitivity of TG is quite different from that of AAS. The former usually measures the samples in the mg-sub-mg range, whereas the latter deals with samples in the range μg -ng. Therefore, the sample weight should be as low as possible to reduce the sensitivity of the AA measurements. TG measurements were performed with solid mercury(II) nitrate. From the shape of the curves obtained with decreasing specimen masses, from the order of 1 mg to 10 μg , it was possible to calculate mass losses. However, at least 0.5 mg of specimen were necessary to draw a thermogram and about 5 mg were necessary for a good thermogram.

The effect of carrier gas flow rate on the AA signal from 0.5 mg of mercury(II) nitrate, with a furnace heating rate of 5°C min^{-1} was investigated in the range 30–100 ml min^{-1} . To rapidly remove the atomic mercury from the light path of the AA the flow rate should be increased as much as possible. However, because the carrier gas blows on the sample vessel, the larger the flow rate becomes, the larger the noise of the thermogram and AA signal. Therefore, 50 ml min^{-1} was chosen as the optimum flow rate of the carrier gas.

The furnace heating rate should be decreased because it is important that the mercury vapour is evolved as slowly as possible. However, it can take too long if the heating rate is too small. The sample was usually pyrolysed at a heating rate of 5°C min^{-1} .

THE ELUCIDATION OF THE VAPORIZATION PROCESSES OF MERCURY COMPOUNDS

Mercury(I) chloride

Figure 4 shows a typical result obtained from the pyrolysis of mercury(I) chloride, Hg_2Cl_2 . Curve (a) shows the temperature change for a heating rate of 5°C min^{-1} . The temperature change is set proportional to time, as shown in this curve, hence the abscissa indicates the temperature. Curve (b) is the TG curve which shows the mass loss of the sample on a scale of weight percent. This gives quantitative information from the thermal decomposition of the sample at some temperature. Curve (c) shows the AA spectral change with respect to the absorbance of Hg (253.7 nm) and indicates whether or not the elemental vapour was evolved at the same temperature as the pyrolysis.

As demonstrated by curve (b), all the specimen sublimed in the range of $130\text{--}230^\circ\text{C}$. On the atomic absorption curve (c), the gas evolved up to 220°C is apparently gaseous mercury, and no further peaks are observed. Below about 220°C , the appearance of mercury vapour approximately coincides with the sublimation of the specimen (curve b). However, the gradual increase in absorbance from about 430°C was not due to mercury vapour because this phenomenon was also observed with an empty cell. And also, when a deuterium lamp was used as a continuous emission source, this increase in absorbance was observed regardless of the presence of the sample. The cause could presumably be scattering of the source light from the heated quartz flow cuvette.

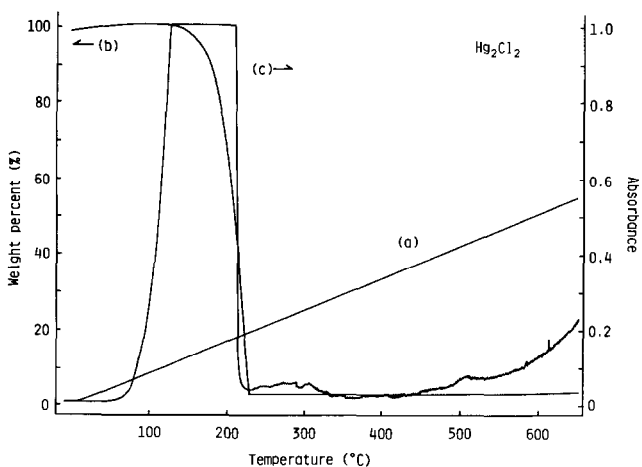
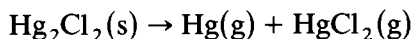

Fig. 4. TG and absorbance versus temperature curves for mercury(I) chloride: (a) temperature; (b) TG; (c) AA.

The following decomposition reaction of mercury(I) compounds is well-known



Curve (c) indicates that this reaction starts at about 50 °C.

Mercury(II) halides

The pyrolysis of mercury(II) chloride, HgCl_2 , was examined, and the results are shown in Fig. 5. Curve (b) indicates that sublimation of this compound starts at about 100 °C and proceeds in one stage, as with mercury(I) chloride. However, there is no evolution of mercury vapour over the whole temperature range during which the sample mass decreased. It was concluded, therefore, that mercury(II) chloride sublimed as HgCl_2 molecules, as expected

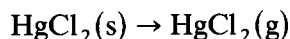

In Fig. 6, results for other mercury(II) halides, HgBr_2 and HgI_2 , are shown. These results are similar to the result of mercury(II) chloride. Thus, it was concluded that mercury(II) halides sublime in the 100–180 °C range as follows

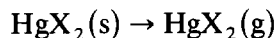

where X = Cl, Br or I.

Whereas normal TG cannot be used to distinguish between mercury(I) chloride and mercury(II) chloride, as shown in Fig. 4(b) and Fig. 5(b), direct

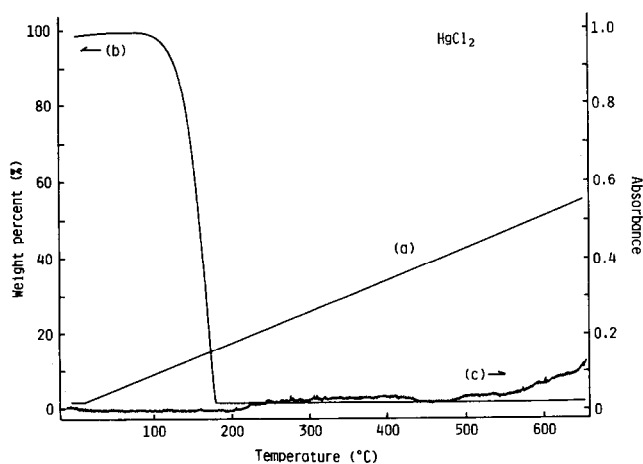

Fig. 5. TG and absorbance versus temperature curves for mercury(II) chloride: (a) temperature; (b) TG; (c) AA.

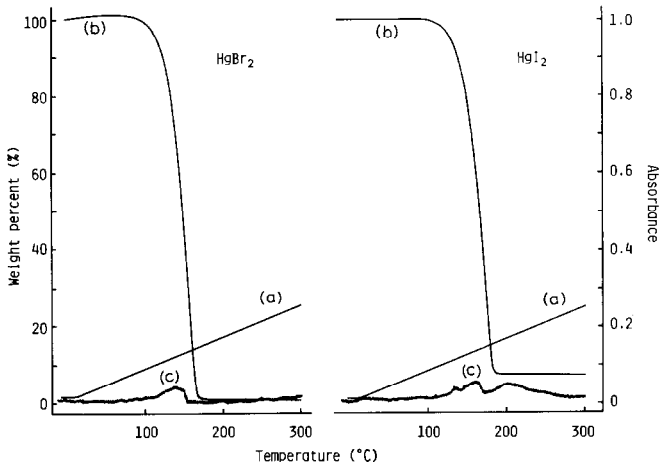

Fig. 6. TG and absorbance versus temperature curves for mercury(II) bromide and iodide: (a) temperature; (b) TG; (c) AA.

combination of this method with AAS can be used for qualitative analytical purposes, as demonstrated by the AA curve shown in Fig. 4.

Mercury(II) nitrate

Solid mercury(II) nitrate, $\text{Hg}(\text{NO}_3)_2 \cdot \frac{1}{2} \sim 1 \text{ H}_2\text{O}$ was measured. As shown in curve (b) in Fig. 7, the pyrolysis starts at 90°C and proceeds in five stages. On curve (b), the gas evolved at 90 and 150°C is either adsorbed or

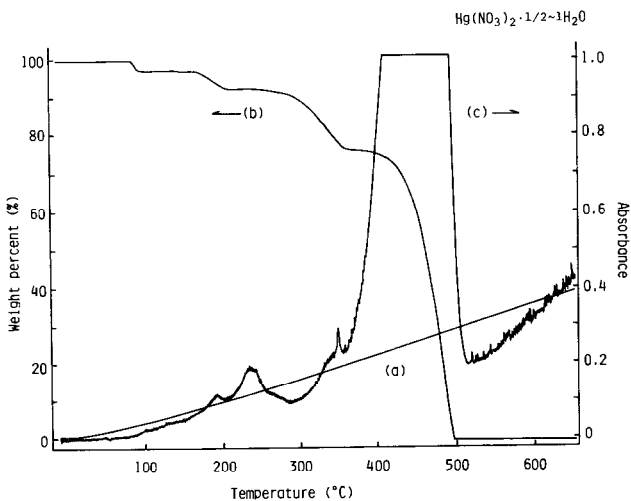
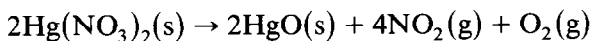

Fig. 7. TG and absorbance versus temperature curves for mercury(II) nitrate hydrate; (a) temperature; (b) TG; (c) AA.

partially combined water. The mass losses at 200 °C (6.0%), 320 °C (15.1%) and 460 °C (78.0%) are presumed to be due to subsequent evolution of nitrogen oxides and mercury gases. Mercury(II) nitrate forms red mercury(II) oxide with gentle heating; stronger heating leaves no residue, because this oxide forms mercury vapour and oxygen above 500 °C [9]. The TG curve (b) above 500 °C clearly shows this decomposition process.

On the other hand, curve (c) indicates that a small amount of mercury vapour is evolved from the solid specimen below 350 °C. The first small peak appears at 200 °C, and two further small peaks are observed. Over the whole temperature range, the appearance of the mercury peaks approximately coincides with the mass losses in curve (b). Therefore, it can be seen that mercury(II) nitrate decomposes step-wise on heating with evolution of mercury vapour. In particular, the TG curve and the corresponding AA curve in the 380–500 °C range clearly show simultaneous decomposition of mercury(II) nitrate to HgO and Hg vapour



However, the calculated and found values for those substances vaporized and those substances remaining at some temperatures are in agreement to within about 5%.

REFERENCES

- 1 J.A. Dean and T.C. Rains (Eds.), *Flame Emission and Atomic Absorption Spectrometry*, vol. 1, Marcel Dekker, New York, 1969, p. 101.
- 2 R.E. Sturgeon and C.L. Chakrabarti, *Prog. Anal. At. Spectrosc.*, 1/2 (1978) 132.
- 3 T. Takada, *Spectrochim. Acta, Part B*, 41 (1986) 999.
- 4 E.R. Prack and G.J. Batiaans, *Anal. Chem.*, 55 (1983) 1654.
- 5 S. Hanamura, B.W. Smith and J.D. Winefordner, *Anal. Chem.*, 55 (1983) 2026.
- 6 T. Kántor, L. Benzúr, J. Sztatisz and E. Pungor, *J. Therm. Anal.*, 22 (1981) 179.
- 7 T. Kántor and L. Benzúr, *J. Anal. At. Spectrosc.*, 1 (1986) 9.
- 8 T. Takada and K. Nakano, *Anal. Chim. Acta*, 107 (1979) 129.
- 9 A. Holderness, *Inorganic and Physical Chemistry*, Heinemann, London, 1961.